

| WIRE ENERGY WITH TECHNOLOGY



ENERGY STORAGE PRODUCTS AND SOLUTIONS 2016

🇨🇳 Shenzhen Wiretech Co., Ltd(China)

☎ 13620919691

☎ 075523251510

✉ office@wiretech.com

🌐 www.wiretech.com

📍 No.602, Block C, Innovation Plaza, No.2007, Pingshan Avenue, Pingshan District,Shenzhen, China.

Wire Energy With Technology

ENTERPRISE DIRECTORY

Sun, Air and Water are three best natural gifts where we firmly believe the clean energy comes from. Wiretech takes its accountability of building stable clean energy with forefront technology wired.



Enterprise introduction

Corporate Culture	01/02
Company Profile	01/02

Brand strength

Core Engineers	03/04
Our advantages	05/06
Certificate & honor	07/08

Product introduction

New products of the year	09/10
Core technology	11/12
Product range	13/48

Solution

Household level scheme	49/49
Enterprise level solutions	50/50
Large project level scheme	51/52

Strategic development planning

Market strategy	53/54
-----------------	-------



COMPANY PROFILE



Enterprise introduction

 2016

■ Vision:

Help people enjoy energy conveniently and efficiently with ingenuity production.



Founded in 2016 and as a high tech group with setting up headquarter in Shenzhen and manufacturing base in Huizhou, Wirentech engineering team who had been working as lithium battery professions in BYD over 10 years before joining in Wirentech, takes advantage of their rich experience in lithium battery industry to develop innovative and creative lithium battery products and solar energy systems to serve the global clean energy needs. Safe and clean, ingenuity and stable are Wirentech's goals to achieve from first to its last!



Wirentech is honored and pride of delivering lithium battery products and solar energy systems world-widely such as United States, United Kingdom, Germany, France, Austria, Australia, Japan, Philippines, South Africa, Ukraine and etc. Thanks to Wirentech's engineering professions and service team as well as advanced production techs and passions, Wirentech are now UL1973, TUV, IEC62133, PSE certified, we firmly believe that three Natural gift energy will eventually be We-energy easily under the help of Wirentech products!

■ Values:

Customer oriented, Stable performance, Continuous innovation.



02

CORPORATE TEAM

Professional

Specializing in the manufacturing of new energy system.

field

Focused

Focus on technological innovation, talent innovation and design innovation.

thought

Engrossed

Concentrate on serving every customer.

service

Specific

Dedicated to producing lithium battery.

innovate





Oriented with Helping people enjoy convenient and comfortable life by providing stable and clean energy, we gather experienced and talented lithium battery engineers, who had been working over ten years in BYD. Stick to First Principle, we try our best to produce the robust product with simplest structure and least materials.

15+years LITHIUM BATTERY MANUFACTURING EXPERIENCE.

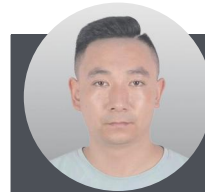

DAVID ZHANG

Core engineer in BYD.
Responsible for development of ESS, EV, E-bus, special vehicle etc.
Over 20GWH products had been participated in for various lithium battery.



WILLIAM ZHU

Over ten years as management in technical dept. in BYD.
Leader in EV battery pack development Xpeng Motors.
Header for the first aluminum welding process automation production line for EV battery.



SHAWN SONG

Over 13 years in BYD EPRI.
Leader for container ess, ESS monitoring cloud platform.
Engaged in USA PJM Frequency regulation project. Frequency regulation ESS in UK.



PAUL LI

2014-2016, Electrical Engineer Huayi Electric.
2016-2019, Senior Engineer in BYD EPRI.
2019-2020, Senior Engineer in Sunwoda.

≡ 03

TECHNICAL TEAM



OEM/ODM
customization



After-sales
service



Manufacturer



Fast delivery



Cost-effective

QUALIFICATION CERTIFICATE



Insisting technological innovation as the core, based on the intelligent technology, with safe and high-quality brand and product to win the recognition of the industry and the market.



≡ 05

NEW PRODUCTS OF THE YEAR

51.2V 100Ah



Active fire arrestor built for pouring out fire.



Smart BMS built for intelligent battery management.



Movable and plug n play design, Minimize the installation time and cost.



A grade LiFePo4 cells with 6000+ cycle life.



Module design makes the users have free choice of power capacity. Max. deliver up to 163.8KW with single module (5.12KWh) at 32pcs parallel connection.



2023

PRODUCT TECHNOLOGY INTRODUCTION

■ App Technology

With high technology, understand the battery situation.

The app is designed to remotely monitor the battery working status, battery status and temperature. Through the App, the battery usage can be accurately checked.

■ Battery Fire Arrestor Technology

Fire arrestor: the use of a new S-type hot aerosol fire extinguishing device: on the one hand, the use of physical cooling---- relying on metal oxides, carbonate endothermic decomposition cooling(The heat released by any fire in a short period of time is limited, if the solid particles in the aerosol can absorb part of the heat released by the fire source in a short period of time,then the temperature of the flame will be reduced,the heat radiated to the combustion surface and used to crack the gasified combustible molecules into free radicals will be reduced,and the combustion reaction will be inhibited to a certain extent.)On the other hand, chemical cooling---- vapor phase, solid phase chemical inhibition.(Under the action of heat, the vaporized metal ions such as Sr,K,Mg or cations that lose electrons decomposed by aerosol fire extinguishing agents exist in the form of steam,multiple chain reactions occur with the active groups H•,•OH and O•in combustion.The solid particles in the hot aerosol fire extinguishing agent can adsorb the chain reaction intermediates•OH,H•and O•,and catalyze their reorganization into stable molecules,thereby interrupting the branched chain reaction of the combustion process.)

≡ 07

HOME ENERGY STORAGE SERIES

WIRE ENERGY BY TECH!



The 30KW rack-mount battery cabinet is composed of 6 sets of 51.2V 100Ah battery modules connected in parallel, the cabinet is IP22. Maximum charge and discharge power can up to 15KW and 30KW. The rack cabinet is equipped with 4 wheels for easy use and movement.



Product introduction

I W51100 Residential storage series

UL1973 certification.

The 51.2V 100Ah rack-mounted battery is a lithium iron phosphate battery module, suitable for residential. Built-in intelligent BMS to ensure the safety and stability of the battery, and can be connected to Bluetooth for use. High-end display design for a clear picture of battery usage. 51.2V 100Ah battery has CE/UL1973 certifications, excellent quality assurance.



Product Introduction

- Energy Scalable: up to 32 units in parallel.
- Software link to PC for vertical monitoring.
- Server racks/Cabinet fits, Easy install, Plug & play.
- Active fire arrestor is integrated for higher protection.
- LCD screen for easiest Data views, Compatible with various inverters.

Product Parameters

Model Name:	W51100	Energy:	51.2V 100Ah(5.12KWh)
Dimensions:	20.47"×9.44"×5.24"	Weight:	43KG
Warranty:	10 Years @ 68°F	Life Time:	15 Years @ 68°F
Cycle life:	6000+	Enclose protection rate:	IP54
Operation Voltage:	40V ~ 58.4V	Max. Charge Voltage:	58.4V
Max. Charge Current:	50A (2.56KW) @77°F	Max. Discharge Current:	100A (5.12KW) @77°F
Energy Scalable:	Max. 32 units in parallel	Communication:	RS232,RS485,CAN
Storage:	50 SOC, test @ 90 Days, recharge if below 52V		

I 30KW Residential storage series



Product Introduction

- Busbar Connection, Compatible with various inverters.
- Active fire arrestor is integrated for higher protection.
- Integrated LED indicator, display the SOC and operating status.
- Packed with high performance LFP single cell, long life, safety and wide temperature range.
- Easy to use and move, plug and play, minimize installation time and cost, and place easily and freely in your warm home.

Product Parameters

Model Name:	30KW	Energy:	51.2V 600Ah(30KWh)
Dimensions:	23.62"×25.59"×49.21"	Weight:	300KG
Nominal Voltage:	51.2V	Life Time:	15 Years @ 68°F
Cycle life:	6000+	Nominal Capacity:	600Ah
Operation Voltage:	44.8V-57.5V	Discharge Current:	15KW
Charge Method:	CC/CV		
Enclose Protection Rate:	IP22		
Discharging Temperature Range:	-4°F-140°F(-20°C-60°C)		

Product introduction

ME-5K Residential storage series

The 51.2V 100Ah stacked battery pack is made of lithium iron phosphate cells. The module design gives the user the freedom to select the power capacity, providing up to 163.8KW with a maximum power of 32 in parallel. It is also equipped with 4 load-bearing rollers, which are easy to use and move.



Product Introduction

- Active fire arrestor is integrated for higher protection.
- Every single battery built with top smart BMS to ME-5K smartly and efficiently.
- Module design makes the users have free choice of power capacity. Max. deliver up to 163.8KW with single module (5.12KWh) at 32pcs parallel connection.
- Easy to use and move, plug and play, minimize installation time and cost, and place easily and freely in your warm home.
- Grade A LiFePo4 cells with strict cell grouping to Minimize cell's voltage/capacity varies to reach it's max.

Product Parameters

Model Name:	ME-5K	Operation Voltage:	44.8V ~ 57.5V
Energy:	51.2V 100Ah (5.12KWh)	Max. Charge Voltage:	57.6V
Dimensions:	17.4" x 19" x 8.66"	Max. Charge Current:	50A (2.56KW) @77°F
Weight:	51KG	Max. Discharge Current:	100A (5.12KW) @77°F
Warranty:	10 Years @ 68°F	Energy Scalable:	Max. 32 units in parallel
LiFe Time:	15 Years @ 68°F	Enclose protection rate:	IP22
Cycle life:	6000+	Communication:	RS232/RS485→ PC software CAN/RS485 → Inverters
Storage:	Recommend stored at above 50% SOC, test @ 90 Days, recharge if below 52V		

Powerwall -WP5K Residential storage series



Product Introduction

- Active fire arrestor is integrated for higher protection.
- Every single battery built with top smart BMS to WP5K smartly and efficiently.
- Module design makes the users have free choice of power capacity. Max. deliver up to 163.8KW with single module (5.12KWh) at 32pcs parallel connection.
- Strong bracket supports the battery firmly and safely mounted.
- Grade A LiFePo4 cells with strict cell grouping to Minimize cell's voltage/capacity varies to reach it's max.

Product Parameters

Model Name:	Powerwall -WP5K	Operation Voltage:	44.8V ~ 57.5V
Energy:	51.2V 100Ah (5.12KWh)	Max. Charge Voltage:	57.6V
Dimensions:	24.8" x 17.32" x 5.91"	Max. Charge Current:	50A (2.56KW) @77°F
Weight:	51KG	Max. Discharge Current:	100A (5.12KW) @77°F
Warranty:	10 Years @ 68°F	Energy Scalable:	Max. 32 units in parallel
LiFe Time:	15 Years @ 68°F	Enclose protection rate:	IP22
Cycle life:	6000+	Communication:	RS232/RS485→ PC software CAN/RS485 → Inverters
Storage:	Recommend stored at above 50% SOC, test @ 90 Days, recharge if below 52V		

Product introduction

I WR4000 Telecom backup

Composed of 15 prismatic 3.2V cells, has been tested at 6000+ deep discharge cycles to 80% DoD @ 68°F with IP54 enclosure, set up RS232, RS485, CAN port. WR4000 supports Max charge current:100A. Supporting max 32 in parallel according to customers' needs. Can support the operation of various household appliances and telecom station backup.100A BMS is set in the battery to detect the overcharge and overdischarge of the current to protect the safety and health of the battery.



Product Introduction

- Parallel up to 32 batteries.
- Grade A LiFePo4 Cells.
- Multiport output, Easy Installation.
- Communication port, Electrical safety.
- Active fire arrestor is integrated for higher protection.

Product Parameters

Model Name:	WR4000	Energy:	48V 100Ah(4.8KWh)
Dimensions:	18.97"×16.53"×7.00"	Weight:	42KG
Warranty:	10 Years @ 68°F	Life Time:	15 Years @ 68°F
Cycle life:	6000+	Enclose protection rate:	IP54
Operation Voltage:	37.5V ~ 54V	Max. Charge Voltage:	54.75V
Max. Charge Current:	100Amps @ 77°F (25°C)	Max. Discharge Current:	100Amps Continuous
Energy Scalable:	32 (Max. Recommended)	Communication:	RS232,RS485,CAN
Storage:	Recommend stored at above 50% SOC, test @ 90 Days, recharge if below 52V		

I WT24200 Residential storage series



Product Introduction

- Energy Scalable: up to 32 units in parallel.
- Software link to PC for vertical monitoring.
- Server racks/Cabinet fits, Easy install, Plug & play.
- Active fire arrestor is integrated for higher protection.
- LCD screen for easiest Data views, Compatible with various.

Product Parameters

Model Name:	WT24200	Energy:	25.6V 200Ah(5.12KWh)
Dimensions:	20.47"×9.44"×8.66"	Weight:	43KG
Warranty:	10 Years @ 68°F	Life Time:	15 Years @ 68°F
Cycle life:	6000+	Enclose protection rate:	IP54
Operation Voltage:	20.0V ~ 29.2V	Max. Charge Voltage:	29.2V
Max. Charge Current:	100A (2.56KW) @77°F	Max. Discharge Current:	150A (3.84KW) @77°F
Energy Scalable:	Max. 32 units in parallel	Communication:	RS232,RS485,CAN
Storage:	50 SOC, test @ 90 Days, recharge if below 26V		

I W5100 Residential storage series

51.2V 100Ah rack mounted LiFePO4 battery, 5.12KW high power is suitable for home energy storage, solar system, etc. Adapt to high temperature and low temperature environment, 6000+(80% DoD @ 68°F) cycle life and long service life. High-end display design to check battery parameters and usage. Connectable to Bluetooth, each battery is integrated with the smart BMS inside, offering great advantages in terms of safety, cycle life, energy density, fast charging, temperature range and environmental protection.



Product Introduction

- Energy Scalable: up to 32 units in parallel.
- Software link to PC for vertical monitoring.
- Server racks/Cabinet fits, Easy install, Plug & play.
- Active fire arrestor is integrated for higher protection.
- LCD screen for easiest Data views, Compatible with various inverters.

Product Parameters

Model Name:	W5100	Energy:	51.2V 100Ah(5.12KWh)
Dimensions:	20.47"×9.44"×8.66"	Weight:	43KG
Warranty:	10 Years @ 68°F	Life Time:	15 Years @ 68°F
Cycle life:	6000+	Enclose protection rate:	IP54
Operation Voltage:	40V ~ 58.4V	Max. Charge Voltage:	58.4V
Max. Charge Current:	50A (2.56KW) @77°F	Max. Discharge Current:	100A (5.12KW) @77°F
Energy Scalable:	Max. 32 units in parallel	Communication:	RS232,RS485,CAN
Storage:	50 SOC, test @ 90 Days, recharge if below 52V		

I R5KLNA Residential storage series



Product Introduction

- Wide input voltage range.
- Natural cooling, low noise.
- Battery reverse connect protection.
- IP65, wall mounted design, Touch screen LCD, saving space.
- Power dispatching and demand side response management.

Model Name:	R5KLNA	AC Voltage:	120V/240V,220V
Dimensions:	16.93"×27.95"×8.27"	Weight:	32KG
Battery Input Range:	48V	Max Charging Current:	120A
Max Discharging Current:	120A	AC Frequency:	50/60Hz
PV Input Power:	7.5kW	Operation Temperature Range:	-25 -60°C
Environment Humidity:	0-95%	PV Voltage Range:	350V/85V - 500V
MPPT Voltage Range:	120V-500V	IP Rank:	IP65/NEMA 3R
Safety :	EN61000-6-1, EN61000-6-3, FCC 15 class B		

I HVE512 Residential storage series

HVE-50Ah series is a high voltage battery that offers multiple energy storage options through an expandable modular design (2-10 modules combined), which further simplifies installation and O&M with multiple smart functions. The safest battery cell technology (LFP) comes with a high charging rate, ensuring superior performance.



Product Introduction

- Original battery active balance technology.
- Flexible capacity options, 5.12KWh to 25.6KWh.
- Easy installation with modular and stacked design.
- Remote diagnosis and real-time data monitoring

Model Name:	HVE512	NO.of series battery:	2
Rated Energy(KWh):	5.12KWh	Usable Energy(KWh):	4.6KWh
Rated Voltage(V) :	102.4V	Voltage Rang(V):	89.6-115.2V
Rated Capacity(Ah):	50Ah	Weight:	72Kg
Charge Current(A):	25(Recommended)/50(Max.)	Discharge Current(A):	25(Recommended)/50(Max.)
Communication:	RS485/RS232/CAN2.0	Dimensions:	33.5"×10.04"×14.09"
Storage Temperature:	-30°C-60°C	Protection Degree:	IP20
Cycle Times:	6000+		

I WIS5K-6K-8K Residential storage series



Product Introduction

- Both PV and grid charge. fast and convenient..
- Peak-shaving mode. reduce the electricity bill.
- High quality LFP battery, Cut-edge CCS pack, Advanced Fire Arrestor equipped.
- Modular and all in one design. compact and elegant appearance. battery is stackble..
- Integrated with stackable battery modules and hybrid storage inverter, connect directly with solar panels, grid and load.

Product Parameters

Input (PV)		Battery modules	
Model Name:	WIS5K/WIS6K/WIS8K	Model Name:	WIS5K/WIS6K/WIS8K
Max.power(kw):	7.5/9/12	Rated output power:	8000W
Max. DC voltage (v):	500	Number of battery :	2/3/4/5/6/7/8
Max.Input current of single MPPT(A)	12	Battery capacity :	
MPPT tracker/strings:	4/1		10.24KWh/15.36KWh/20.48KWh/25.6KWh/30.72KWh/35.84KWh/40.96KWh
Operation Mode:	Grid-connected/Off-grid	Operating temperature :	-20°C-60°C
Communication interface:	CAN/RS485	Storage temperature :	0°C-45°C
Parallel:	3	Humidity :	5%-95%
Max. efficiency:	≥98.2%	Cooling strategy :	Natural Cooling
Operation Temp:	-20°C-60°C	Enclosure protection rate :	IP20
Relative humidity :	0-95%(non-condensing)	Communication interface:	CAN/RS485
Dimensions :	16.93"×8.66"×27.95"		

≡ 08

COMMERCIAL ENERGY STORAGE SERIES

SUPPORT OEM/ODM CUSTOMIZATION



The container storage system is based on a modular design. It can be configured to match the required power and capacity requirements of client's application. Container storage system allows fast installation, safe operation and controlled environmental conditions. Support multiple battery input to improve battery cycle life. Support battery management system and comprehensive thermal management.



I WenerMeta-1.1-30P Commercial energy storage series

This is an one-stop integration system and configured with battery module, PCS, STS(optional),control system, fire control system, temperature control system and monitoring system.The battery cluster consists of modules connected in series,and the whole battery system is controlled by BCM to monitor the cluster voltage and current in real time.The whole system is plug-and-play, easy to be transported, installed and maintained.



Product Introduction

- Automobile-grade, high-performance LiFePo4 battery to ensure high safety and reliability.
- Protection class IP55, suitable for outdoor use,Four layers of safety protection design for higher safety and reliability.
- One-button start, automatic operating and it support multiple parallel connection, Real-time data backup,Remote viewing service.
- Intelligent temperature control to ensure the optimal temperature environment and lower system power consumption.

Product Parameters

Model Name:	WenerMeta-1.1-30P	Cell Type:	LFP-220Ah
Dimensions:	74.69" x 82.36" x 48.46"	Weight:	2500KG
Warranty:	3 Years	Cycle life:	5 Years or more than 3000 times
Noise:	≤75dB	Battery Voltage Range:	268.8V-864V
IP Protection Rating:	IP55 (Battery room)	Seismic Intensity Rating:	8 degree (IEC60980)
Anti-corrosion Grade:	3C	Operating Temperature:	-20°C-50°C
Relative Humidity:	0-95% (Non-condensing)	Altitude :	<2000m
Battery Capacity(BOL):	67KWh-168KWH		

I Powmax-100K Commercial energy storage series



Product Introduction

- Automobile-grade, high-performance LiFePo4 battery to ensure high safety and reliability.
- Protection class IP55, suitable for outdoor use,Four layers of safety protection design for higher safety and reliability.
- One-button start, automatic operating and it support multiple parallel connection, Real-time data backup,Remote viewing service.
- Intelligent temperature control to ensure the optimal temperature environment and lower system power consumption.

Product Parameters

Model Name:	Powmax-100K	Cell Type:	LFP-220Ah
Dimensions:	74.69" x 82.36" x 48.46"	Weight:	2500KG
Warranty:	3 Years	Cycle life:	5 Years or more than 3000 times
Noise:	≤75dB	Battery Voltage Range:	268.8V-864V
IP Protection Rating:	IP55 (Battery room)	Seismic Intensity Rating:	8 degree (IEC60980)
Anti-corrosion Grade:	3C	Operating Temperature:	-20°C-50°C
Relative Humidity:	0-95% (Non-condensing)	Altitude:	<2000m
Battery Capacity(BOL):	67KWh-168KWH		

I PP500 Commercial energy storage series

PP500 All in one outdoor energy storage cabinet, equipped with automotive-grade high-performance lithium iron phosphate batteries, the battery is composed of high-reliability automotive process modules in series. Battery module、 Power Conversion System(PCS)、 Power Distribution Unit(PDU)、 Automatic fire protection system(AFS)、 Temperature control system(TCS)、 Intelligent control system(IMS)、 Maximum Power Point Tracking(MPPT) all in one.



Product Introduction

- The system can realize on and off grid and charge discharge bi-directional.
- Powerful energy management system, it can realize energy self-management, intelligent operation, less maintenance.
- The microgrid system can be equipped with the world's leading energy storage system to realize residual power storage.
- Active and reactive power regulation of energy storage converter: The monitoring system can monitor the state of grid, PCS and energy storage device in real time, the system can quickly respond to the grid and realize demand management and peak shaving.

Product Parameters

Model Name:	PP500	Battery Rated Voltage :	768V
Dimensions:	23.62"×25.59"×74.8"	Weight:	800Vdc
Warranty:	5 Years @ 68°F	Life Time:	15 Years @ 68°F
Cycle life:	6000+	Enclose protection rate:	IP54
Battery Energy:	495KWH	Max.DC Input Current:	1600A
Working temperature:	-30°C-55°C	Storage temperature:	-40°C-60°C
IP Level:	IP23	Max.DC Input Voltage :	800Vdc
Storage:	50 SOC, test @ 90 Days		

I W-1MWH-500KW Commercial energy storage series



Product Introduction

- Hybrid 1000Kwh LFP/500 PCS All In One System.
- EMS system integrating for remote monitor and control.
- CCTV is available for internal recording and monitoring.
- HVAC system keeps the battery modules working in ideal temperature.

Product Parameters

Model Name:	W-1MWH-500KW	Battery Cluster Capacity:	280Ah
System Capacity:	1000KWh(1400Ah)	Battery Charge Current:	≤140A
Dimensions:	238.5"×95.98"×114.02"	Battery Discharge Current:	≤280A
Weight:	16000KG	PCS:	500KW 400V/480V
Power Output:	AC480V-50Hz-500KW	MPPT:	300KW
Operation Mode:	Grid-connected/Off-grid	Air Conditioner:	12.5KW
Cycle life:	TCP/IP	Transformer:	AC480-AC380
Black-start:	YES	UPS:	AC220V
Battery Type:	LiFePo-280Ah	ACDC :	AC220V-DC24V
Operation Temp:	-20°C-55°C	Fire Extinguishing System:	HFC-227ea(40L)
Permissible Humidity :	5°C-95°C	Permissible Altitude:	≤2000m
Battery Norminal Voltage:	716.8V	Battery Voltage Range:	627.2V-806.4V
Number Of Battery Clusters:	5		

≡ 09

GOLF CART SERIES

SUPPORT OEM/ODM CUSTOMIZATION



The 64V 100Ah battery module is composed of safe and clean lithium iron phosphate cells, which is perfect for golf carts power backup. More than 6000 cycles, with 0.2C charge and discharge rate, at 25 °C, 80% DOD. can Be connected to Bluetooth, each battery integrates internal intelligent BMS, which can ensure the safety and life of the battery. The battery module has stable and compact structure, can withstand a very high level of vibration and shock. The battery has overcharge protection, overdischarge protection, overcurrent protection and short circuit protection.

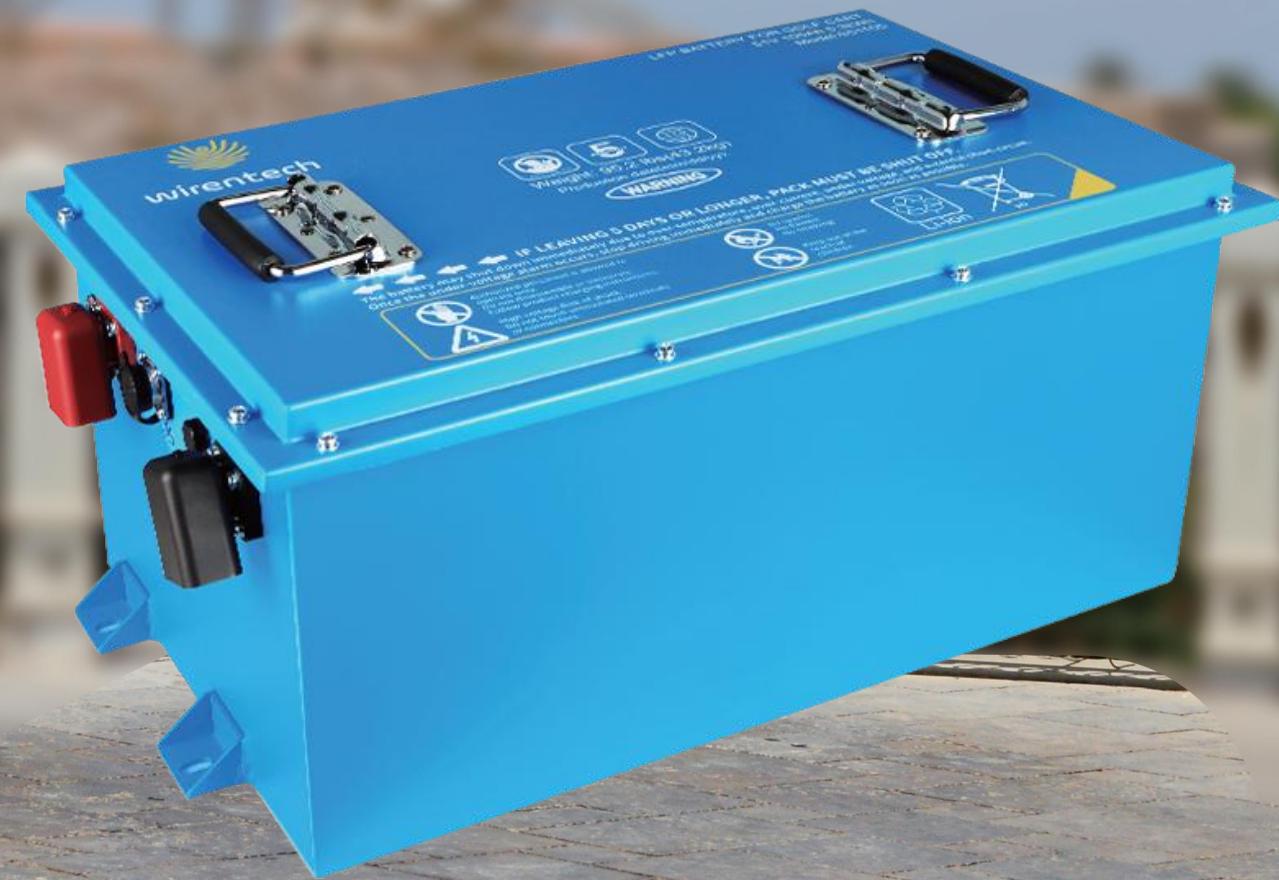

I WG5150 Golf energy storage series

WG5150 (51V 50Ah) battery module has a unique and exquisite appearance design for golf cart energy storage. It has the advantages of light weight, small size and large energy, which is convenient to carry and use. Support series and parallel connection (Max.4 recommended) and Bluetooth connection, each battery integrates internal intelligent BMS, which can ensure the safety and life of the battery.



Product Introduction

- Light weight and small size,GPS - Optional ,high density.
- Bluetooth for monitoring,Check product data information.
- Voltage protection,Current protection,Short circuit protection.
- Temperature protection,Multi-power protection,Low power consumption.

Product Parameters

Model Name:	WG5150	Operation Voltage:	44.8V ~ 57.5V
Energy:	51.2V 50Ah(2.56KWh)	Discharge Current:	100Amps Continuous
Dimensions:	8.19" x 10.94" x 7.01"	Peak Current:	300Amps
Weight:	20Kg	Operation Voltage:	40V ~ 57.5V
Charge Method:	CC/CV	Recommended Charging Current:	50Amps
LiFe Time:	15 Years @ 68°F	Enclose protection rate:	IP65
Cycle life:	6000+	Energy Scalable:	4 (Max. Recommended)
Discharging Temperate Range:	-4° ~ 140°F (-20°C- 60°C)		

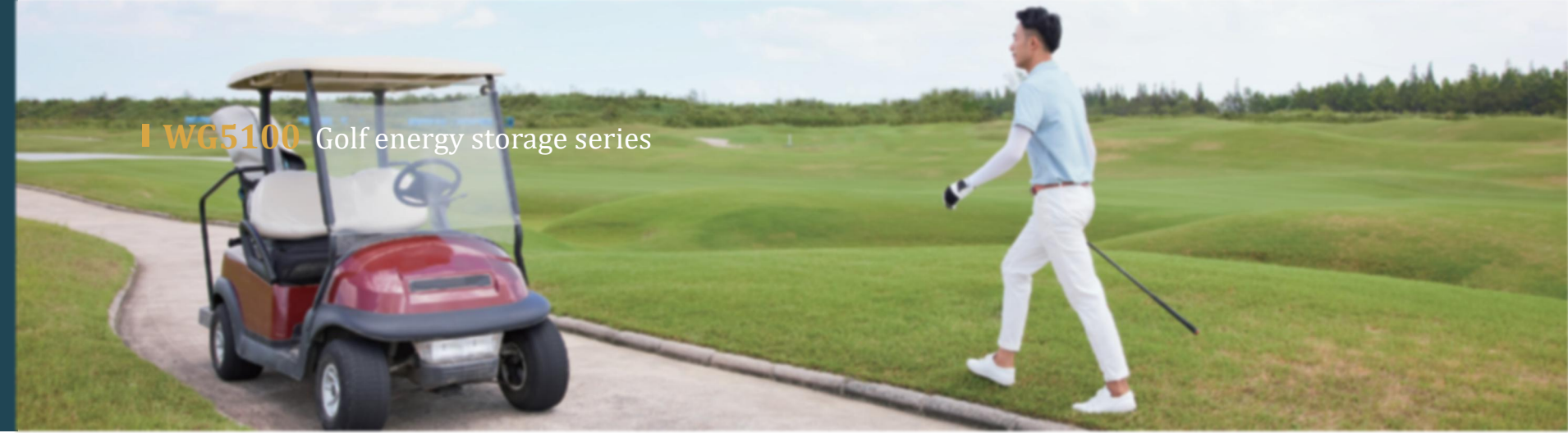

I WG5100 Golf energy storage series

Product Introduction

- Multi usages for golfcart, RV, Marine.
- Unique design and drop-in replacement.
- 100A BMS,High surge current available.
- Bluetooth for monitoring,Check product data information.

Product Parameters

Model Name:	WG5100	Energy:	51.2V 105Ah(5.3KWh)
Dimensions:	19.17"×11.81"×8.46"	Weight:	51KG
Life Time:	10 Years @ 68°F	Communication:	CAN,Bluetooth
Cycle life:	6000+	Enclose protection rate:	IP65
Operation Voltage:	44.8V ~ 57.5V	Max. Charge Voltage:	57.6V
Max. Charge Current:	100Amps @ 77°F (25°C)	Max. Discharge Current:	100Amps Continuous
Storage:	50 SOC, test @ 90 Days, recharge if below 52V		

I WG5100 Golf energy storage series

WG5100 LiFePO4 battery module, 51.2V 100Ah is perfect for golf cart battery energy storage. The battery system consists of a battery rack and cells, each integrated with the intelligent BMS inside, which has great advantages in terms of safety, cycle life, energy density, fast charging, temperature range and environmental protection. The battery can be Bluetooth connected and is compatible with most inverters on the market.



Product Introduction

- Multi usages for golfcart, RV, Marine.
- Unique design and drop-in replacement.
- 100A BMS,High surge current available.
- Bluetooth for monitoring,Check product data information.

Product Parameters

Model Name:	WG5100	Energy:	51.2V 105Ah(5.3KWh)
Dimensions:	19.17"×11.81"×8.46"	Weight:	51KG
Life Time:	10 Years @ 68°F	Communication:	RS232,RS485,CAN,Bluetooth
Cycle life:	6000+	Enclose protection rate:	IP54
Operation Voltage:	44.8V ~ 57.5V	Max. Charge Voltage:	57.6V
Max. Charge Current:	100Amps @ 77°F (25°C)	Max. Discharge Current:	100Amps Continuous
Storage:	50 SOC, test @ 90 Days, recharge if below 52V		



I WG64100 Golf energy storage series

Product Introduction

- Compact structure with holder,Over 10 years design life.
- Green energy without metal contaminant High capacity.
- Withstanding very high level of vibrations and shocks.
- Steady output voltage,Low self-discharge,Temperature protection.

Product Parameters

Model Name:	WG64100	Nominal Voltage:	64V
Nominal Capacity:	100Ah	Energy:	64V 100Ah(6.4KWh)
Dimensions:	27.56" x 13.39" x 6.3"	Min.Capacity:	95Ah
Weight:	63Kg	Max.Charge Voltage:	73.0V
Charge Method:	CC/CV	Discharge Cut-off Voltage:	44.0V
Charge Temperature:	0°C-45°C	Discharge Temperature:	-20°C-65°C
Storage Temperature:	-10°C-45°C	Continuous Charge Current:	Max.100A
Peak Instant Discharge Current(5 Seconds):	400A		

≡ 10

RV-C LIFEP04 BATTERY

SUPPORT OEM/ODM CUSTOMIZATION



51.2V 300Ah composed of 16 prismatic 3.2V cells, has been tested at 6000+ deep discharge cycles to 80% DoD @ 68°F with IP54 enclosure. It has RS485、CAN port and supports Max charge current:100A ,Max discharge Current:100A.Can be applied to Golf carts mainly .100A BMS is set in the battery to detect the overcharge and overdischarge of the current to protect the safety and health of the battery.



WT51200 RV energy storage series

The 51.2V 202Ah battery is composed of safe and clean lithium iron phosphate cells, and the 10.34KW high power is suitable for golf carts. Tested for 6000+ deep discharge cycles, it reaches 80% DoD at 68°F at IP54 rating. It has RS485, CAN port, supports maximum charging current: 100A, maximum discharge current: 100A. 100A BMS is set in the battery to detect overcharge and overdischarge of current and protect the safety and health of the battery.



Product Introduction

- Vibration and shock-resistant.
- Green energy without contaminants.
- Handle design, easy to use and carry.
- Long Life & Deep Cycle, Low Self-consumption, Advanced Technology.
- Excellent discharge characteristics. Have low internal resistance and high flat voltage characteristics during strong current discharge, which ensures a wider application field.

Product Parameters

Model Name:	WT51200	Rated Voltage:	51.2V
Dimensions:	43.7"×8.27"×12.2"	Voltage Range:	44.8-58.4V
Rated Capacity:	202Ah(10.34KWh)	Continue Discharge Current :	≤200A 1C
Continue Charge Current:	≤200A 1C	Discharge Temperature:	-20-55°C
Charge Temperature:	0-50°C	Weight:	About 90Kg
Communication:	RV-C/Bluetooth	Pre-heating:	300W
Pre-charge:	Yes	Circuit Breaker:	300A
LCD Screen:	Yes	Energy Expansion:	4 units in Series MAX.



WT51300 RV energy storage series

Product Introduction

- Convenient Battery Replacement.
- Green energy without contaminants.
- Bluetooth for monitoring, Check product data information.
- Long Life & Deep Cycle, Low Self-consumption, Advanced Technology.
- Excellent discharge characteristics. Have low internal resistance and high flat voltage characteristics during strong current discharge, which ensures a wider application field.

Product Parameters

Model Name:	WT51300	Rated Voltage:	51.2V
Dimensions:	27.36"×16.93"×13.78"	Voltage Range:	44.8-58.4V
Rated Capacity:	300Ah(15.36KWh)	Continue Discharge Current :	≤300A 1C
Continue Charge Current:	≤300A 1C	Discharge Temperature:	-20-55°C
Charge Temperature:	0-50°C	Weight:	About 130Kg
Communication:	RV-C/Bluetooth	Pre-heating:	300W
Pre-charge:	Yes	Circuit Breaker:	300A
LCD Screen:	Yes	Energy Expansion:	4 units in Series MAX.

Product introduction

WT12400 RV energy storage series

12.8V 410Ah lithium iron phosphate battery module, 5.24KW power is very suitable for RV, golf car energy storage. Connected to Bluetooth, built-in top intelligent BMS system for monitoring, management, recording of all individual unit parameters, to ensure the use of safety and life of the battery. Unique handle design, easy to carry and use.



Product Introduction

- Convenient Battery Replacement.
- Robust performance, Environmentally Friendly.
- Long Life & Deep Cycle, Low Self-consumption. ,Advanced
- Bluetooth for monitoring, Can Connect APP To Check, Battery Information.

Product Parameters

Model Name:	WT12400	Rated Voltage:	12.8V
Dimensions:	20.87"×11.81"×9.06"	Voltage Range:	11.2V-14.6V
Rated Capacity:	410Ah(5.24KWh)	Continue Discharge Current :	≤200A 0.5C
Continue Charge Current:	≤200Ah 0.5C	Discharge Temperature:	-20-55°C
Charge Temperature:	0-50°C	Weight:	About 48Kg
Communication:	RV-C/Bluetooth	Pre-heating:	300W
Pre-charge:	Yes	Circuit Breaker:	300A
LCD Screen:	Yes	Energy Expansion:	4 units in Series MAX.

W12300 RV energy storage series



Product Introduction

- Convenient Battery Replacement.
- Robust performance, Environmentally Friendly.
- Bluetooth for monitoring, Can Connect APP To Check, Battery Information.
- Long Life & Deep Cycle, Low Self-consumption ,Advanced Technology.

Product Parameters

Model Name:	W12300	Operation Voltage:	10V ~ 14.4V
Energy:	12.8V 300Ah(3.84KWh)	Discharge Current:	200A
Dimensions:	18.9"× 8.82"× 8.74"	Housing:	ABS case
Weight:	28Kg	Operation Voltage:	40V ~ 57.5V
Charge Method:	CC/CV	Charge current:	100A
LiFe Time:	15 Years @ 68°F	Enclose protection rate:	IP65
Cycle life:	6000+	Energy Scalable:	4 units series & parallel connection
Optional Performance:	Bluetooth, LCD/Meters, Pre-heating		

≡ 11

LEAD ACID REPLACEMENT SERIES

SUPPORT OEM/ODM CUSTOMIZATION



12V 140Ah battery module adopts advanced lithium iron phosphate battery and M8 terminal, its cycle life and use time are higher than lead-acid batteries , and it is safe and clean without metal contaminant, which is a good green energy battery. Each battery has a built-in BMS , which can better ensure the safety and service life of the battery. Widely used for RVs, golf carts, marine and so on. It can be connected to Bluetooth and is compatible with most inverters on the market.



Product introduction

I W12100 Yacht Range

UL1973 certification.

The 12V 100Ah battery module adopts advanced lithium iron phosphate technology and M8 terminal. Available in white and black, its cycle life and long-term use are higher than lead-acid batteries. Built-in BMS system can better ensure battery safety and long life. Suitable for RVs, golf carts, marine and so on. It can be connected to Bluetooth and is compatible with most inverters on the market. It has CE/UL1973 certifications, excellent quality assurance.

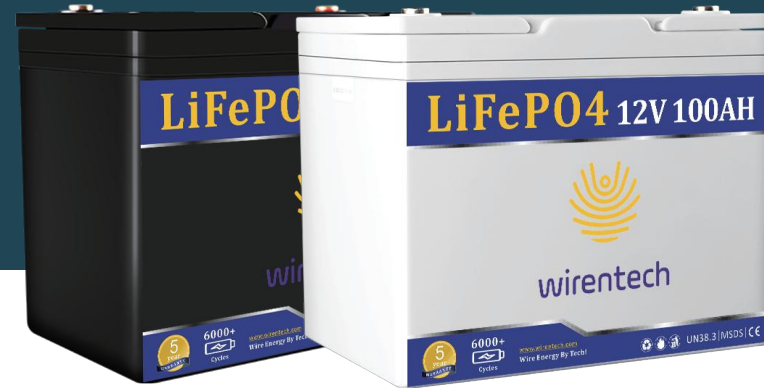

Product Introduction

- Long Life and Deep Cycle.
- Drop in Lead-acid replacement @All group sizes.
- IP65 water-resistant with Robust Structure and neat built.
- Wiretech Bluetooth App enables linking with batteries for SOC voltage ,temp, current monitoring.

Product Parameters

Model Name:	W12100/ W12200/ W12300	Energy:	12.8V 100Ah/200Ah/300Ah
Cycle life:	6000+	Discharge Current:	100A
Charge Method:	CC/CV	Charge current:	100A
Weight:	10/ 20/ 28KG	Operation Voltage:	10V ~ 14.4V
LiFe Time:	15 Years @ 68°F	Housing:	ABS case
Optional Performance:	Bluetooth, LCD/Meters, Pre-heating	Enclose protection rate:	IP65
Energy Scalable:	4 units series & parallel connection		
Dimensions:	10.24"x 6.61"x 8.23"/ 18.9"x 6.69"x 9.45"/ 20.47"x 10.51"x 8.66"		

I W12140 Yacht Range

UL1973 certification.



Product Introduction

- Convenient Battery Replacement.
- Robust performance, Environmentally Friendly.
- Bluetooth for monitoring, Can Connect APP To Check, Battery Information.
- Long Life & Deep Cycle, Low Self-consumption , Advanced Technology.

Product Parameters

Model Name:	W12140	Operation Voltage:	10V ~ 14.4V
Energy:	12.8V 140Ah(1.79KWh)	Enclose protection rate:	IP65
Dimensions:	12.99"x 6.89"x 8.86"	Housing:	ABS case
Weight:	18Kg	Optional Performance:	Bluetooth, LCD/Meters, Pre-heating
Charge Method:	CC/CV	Charge current:	80A
LiFe Time:	15 Years @ 68°F	Cycle life:	6000+
Energy Scalable:	4 units series & parallel connection		
Discharge current:	200A, 500A for 30 Seconds, 600A OCP delay for 3 Seconds		

Product introduction

I W12195 Yacht Range

UL1973 certification

W12195 composed of (4) UL listed prismatic 3.2V cells, has been tested at 6000+ deep discharge cycles to 80% DoD @ 68°F with IP65 waterproof rubber shell. W12195 support 80a charge, 200a discharge. And supports four groups in parallel, then can be used in a wide variety of scenarios, such as: Golf carts, RVs, Residential energy storage, Boats. 100a BMS is set in the battery to detect the overcharge and overdischarge of the current to protect the safety and health of the battery.



Product Introduction

- Convenient Battery Replacement.
- Robust performance, Environmentally Friendly.
- Bluetooth for monitoring, Can Connect APP To Check, Battery Information.
- Long Life & Deep Cycle, Low Self-consumption, Advanced Technology.

Product Parameters

Model Name:	W12195	Energy:	12.8V 195Ah(2.49KWh)
Cycle life:	6000+	Discharge Current:	200A
Dimensions:	12.99"x6.89"x8.86"	Charge current:	80A
Weight:	20KG	Operation Voltage:	10V ~ 14.4V
Charge Method:	CC/CV	Housing:	ABS case
LiFe Time:	15 Years @ 68°F	Enclose protection rate:	IP65
Optional Performance:	Bluetooth, LCD/Meters, Pre-heating		
Energy Scalable:	4 units series & parallel connection		

I W3660 Yacht Range

UL1973 certification



Product Introduction

- Convenient Battery Replacement.
- Robust performance, Environmentally Friendly.
- Bluetooth for monitoring, Can Connect APP To Check, Battery Information.
- Long Life & Deep Cycle, Low Self-consumption, Advanced Technology.

Product Parameters

Model Name:	W3660	Operation Voltage:	30V ~ 43.2V
Energy:	38.4V 60Ah(2.3KWh)	Enclose protection rate:	IP65
Dimensions:	12.99"x6.77"x8.85"	Maximum Current:	60Amps
Weight:	37.5 Pounds (17±0.2Kg)	Discharge Current:	100Amps Continuous
Charge Method:	CC/CV	Recommended Current:	30Amps
LiFe Time:	15 Years @ 68°F	Cycle life:	6000+
Energy Scalable:	4 (Max. Recommended)		
Recommend Discharge Cut-off Voltage:	33.6V		

11 USER SOLUTIONS

Home energy storage solution

With the energy crisis increasing, energy independence is becoming more and more important. Solar+energy storage surely is the best solution so far. Stable lithium battery storage system plays key role to be energy independent.

- High efficiency solar system with LFP battery.
- Flexible energy option for different energy demands.
- Smart BMS control to ensure battery stable performance.
- Home smart energy management terminal
- Power dispatching and demand side response management
- Distributed virtual power plant node

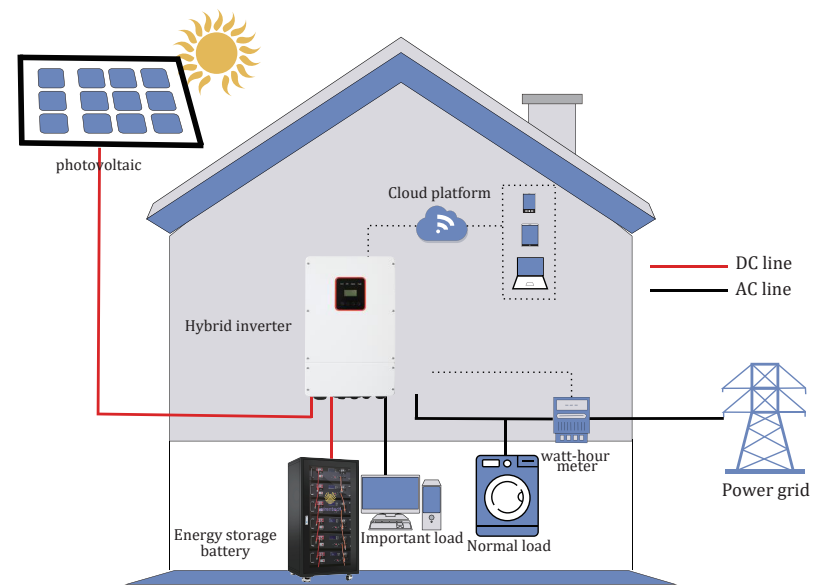

12 USER SOLUTIONS

Commercial energy storage solutions

Energy storage system can be used to realize peak valley arbitrage if the peak valley price of industry and commerce is relatively high. In addition, industrial and commercial energy storage can also reduce the transformer capacity charge, reduce the transformer maximum and power demand charge, delay the construction of user distribution capacity and save expenses for enterprises and industry and commerce as standby power supply

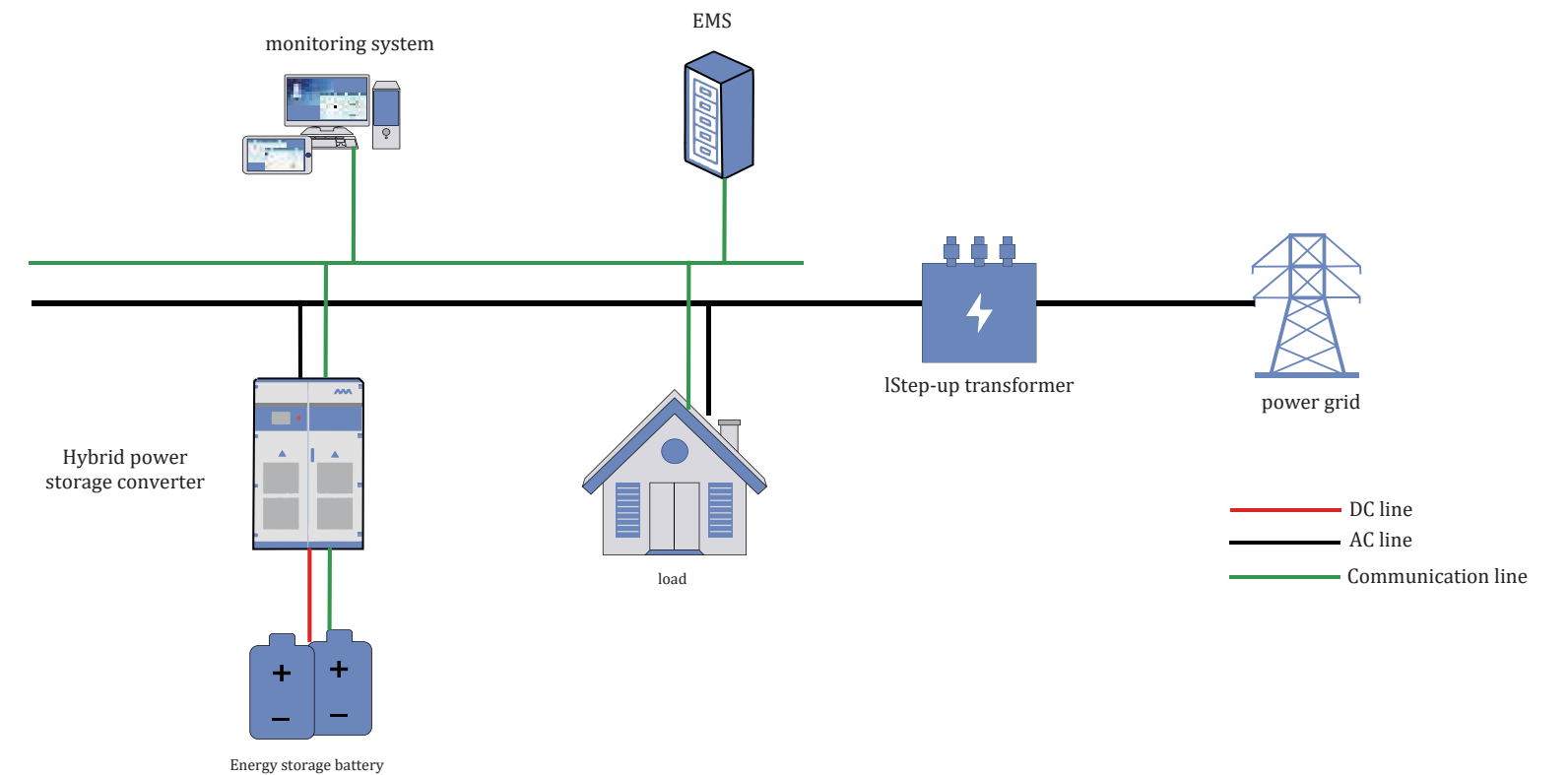

13 USER SOLUTIONS

Energy storage solutions for photovoltaic power plants

The energy storage system can be used to retrofit the existing photovoltaic power stations with high grid cost. Solve the problem of surplus energy in photovoltaic power plants, eliminate the random fluctuation of photovoltaic, and improve the quality of power and energy output of photovoltaic power plants. The PV power station will gradually become adjustable power, generating 96 point power forecast report, gradually allowing the PV power station to participate in peak regulation and frequency regulation and other auxiliary services.

AC bus scheme

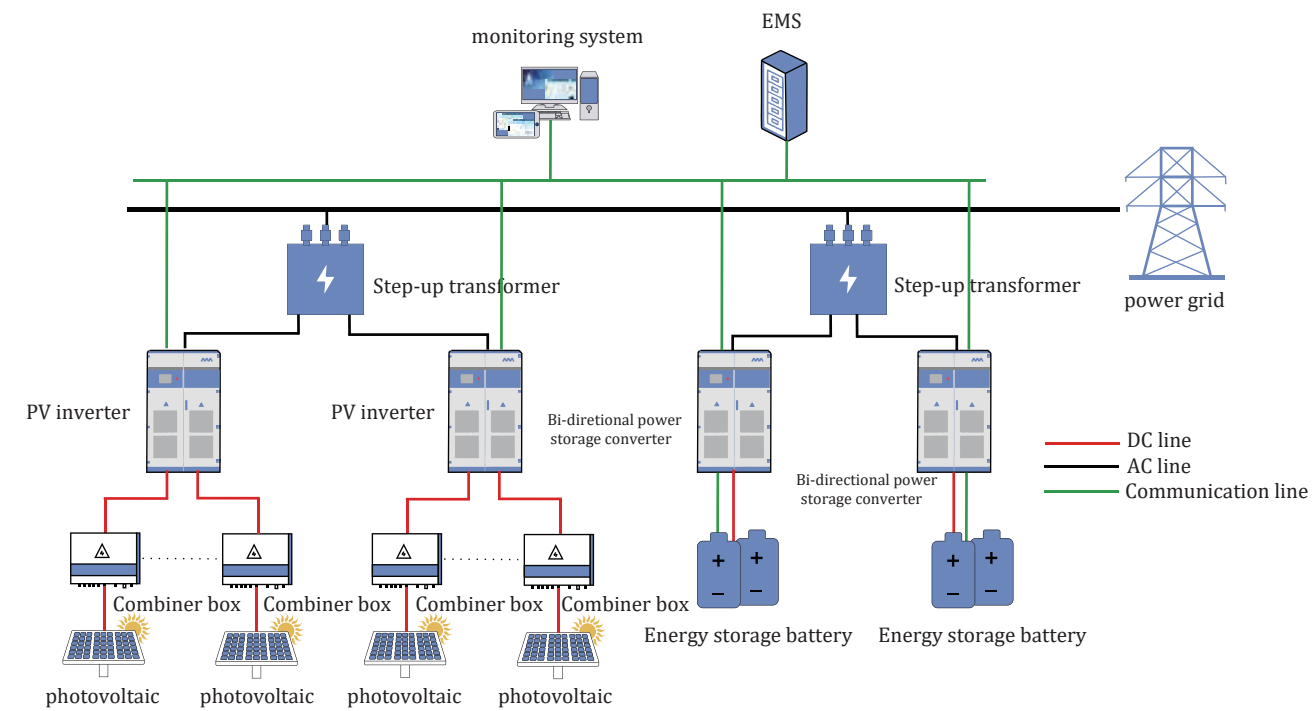

DC bus scheme

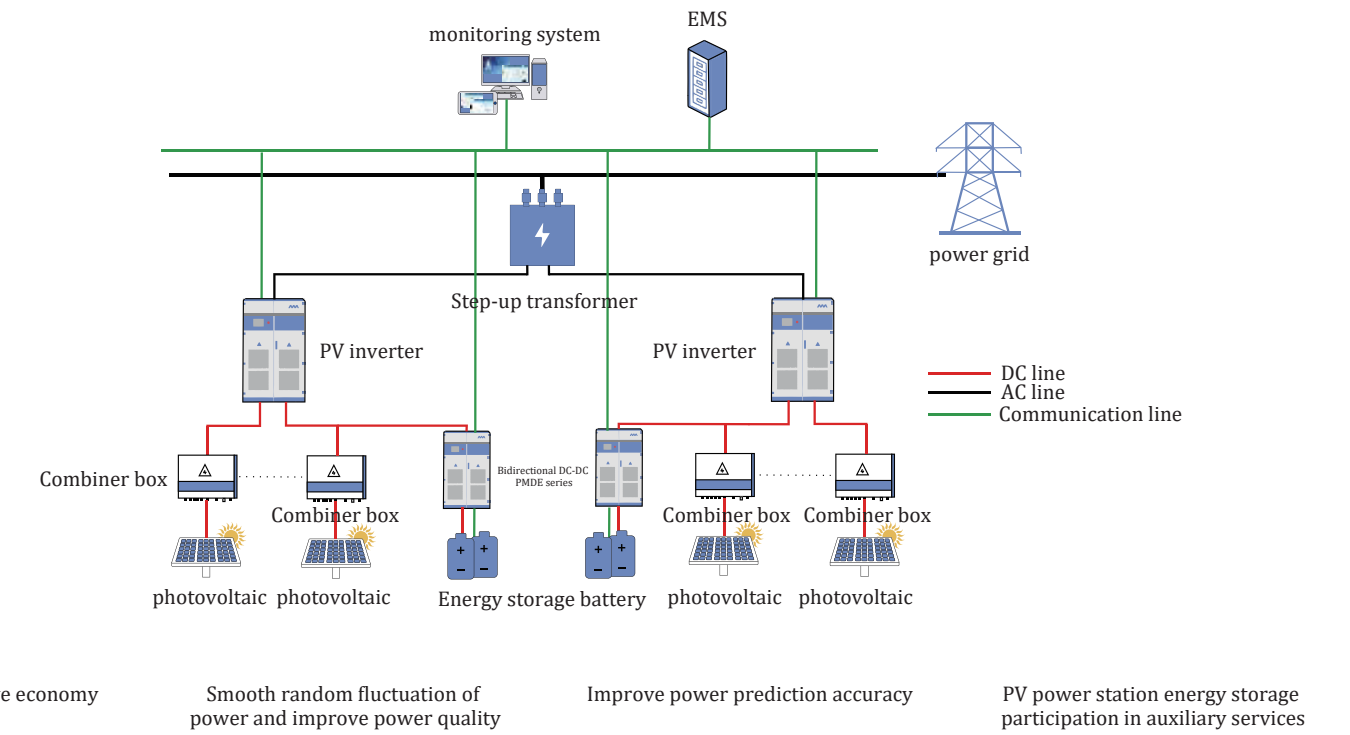

STRATEGIC DEVELOPMENT PLANNING



Wiretech products have been sold to over 70 countries and regions in the United State, Europe, the Middle East, Africa, and Southeast Asia. Our goal is trying to light the every corner of the world with the stable Wiretech storage system.

Improving enterprise value and competitiveness with quality, strive to be the best and most trusted lithium battery enterprise in the world, and base on the global market. Let our products be installed all over the world, every household. We are proud and striving to make end consumers love and benefit from wirentech products.

Achievements

- Operation Center
- R&D base
- Technical team
- Sales team
- Strategic partners
-